



RXM-869-ES  
RXM-916-ES



WIRELESS MADE SIMPLE®

## ES SERIES RF RECEIVER MODULE DATA GUIDE

### DESCRIPTION

Housed in a tiny SMD package, the ES Series offers an impressive combination of features, performance and cost-effectiveness. The ES utilizes an advanced synthesized FM / FSK architecture to provide superior performance and noise immunity when compared to AM / OOK solutions. An outstanding 56kbps maximum data rate and wide-range analog capability make the ES Series equally at home with digital data or analog sources such as audio. A host of useful features including RSSI, PDN, and an audio reference are provided. ES Series components will be available in a wide range of frequencies to take full advantage of worldwide applications. The ES Series requires no tuning or external RF components (except an antenna).

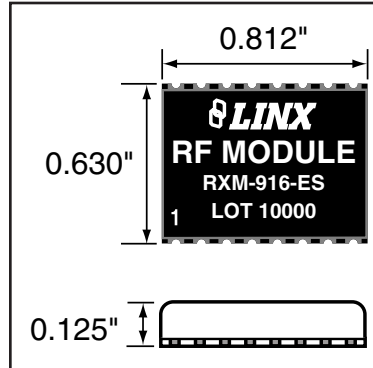

Figure 1: Package Dimensions

### FEATURES

- Ultra-compact SMD package
- FM / FSK modulation for outstanding performance
- High noise immunity
- Precision synthesized architecture
- Excellent sensitivity
- Low current consumption
- High 56,000bps data rate
- Direct interface to analog and digital sources
- Wide-range analog capability
- No tuning or external RF components required
- RSSI and power-down lines

### APPLICATIONS INCLUDE

- Wireless Data Transfer
- Wireless Analog / Audio
- Home / Industrial Automation
- Keyless Entry
- Remote Control
- Fire / Security Alarms
- Telemetry
- Remote Status Sensing
- RS-232 / 485 Data Links
- MIDI Links
- Long-Range RFID

### ORDERING INFORMATION

| PART #                                     | DESCRIPTION                  |
|--|------------------------------|
| TXM-869-ES                                 | ES Series Transmitter 869MHz |
| TXM-916-ES                                 | ES Series Transmitter 916MHz |
| RXM-869-ES                                 | ES Series Receiver 869MHz    |
| RXM-916-ES                                 | ES Series Receiver 916MHz    |
| EVAL-***-ES                                | Basic Evaluation Kit         |
| MDEV-***-ES                                | Master Development System    |
| *** = Frequency                            |                              |
| Receivers are supplied in tubes of 25 pcs. |                              |

# ELECTRICAL SPECIFICATIONS

| Parameter                    | Designation      | Min.                  | Typical             | Max.                  | Units             | Notes |
|------------------------------|------------------|-----------------------|---------------------|-----------------------|-------------------|-------|
| <b>POWER SUPPLY</b>          |                  |                       |                     |                       |                   |       |
| Operating Voltage            | V <sub>CC</sub>  | 4.5                   | 5.0                 | 5.5                   | VDC               | –     |
| Supply Current               | I <sub>CC</sub>  | 5.5                   | 6.0                 | 6.5                   | mA                | –     |
| Power-Down Current           | I <sub>PDN</sub> | –                     | 50.0                | –                     | µA                | 4     |
| <b>RECEIVER SECTION</b>      |                  |                       |                     |                       |                   |       |
| Receive Frequency:           | F <sub>C</sub>   | –                     | –                   | –                     | –                 | –     |
| RXM-869-ES                   |                  | –                     | 869.85              | –                     | MHz               | –     |
| RXM-916-ES                   |                  | –                     | 916.48              | –                     | MHz               | –     |
| Center Frequency Accuracy    | –                | -60                   | –                   | +60                   | kHz               | –     |
| LO Frequency:                | F <sub>LO</sub>  | –                     | –                   | –                     | –                 | –     |
| RXM-869-ES                   |                  | –                     | 859.15              | –                     | MHz               | –     |
| RXM-916-ES                   |                  | –                     | 905.78              | –                     | MHz               | –     |
| IF Frequency                 | F <sub>IF</sub>  | –                     | 10.7                | –                     | MHz               | –     |
| Spurious Emissions           | –                | –                     | -75                 | -50                   | dBm               | 1     |
| Receiver Sensitivity         | –                | -92                   | -97                 | -102                  | dBm               | 2     |
| Noise Bandwidth              | N <sub>3dB</sub> | –                     | 280                 | –                     | kHz               | –     |
| Audio Bandwidth              | –                | 20                    | –                   | 28,000                | Hz                | 3,4   |
| Audio Output Level           | –                | –                     | 360                 | –                     | mV <sub>P-P</sub> | 4,5   |
| Data Rate                    | –                | 200                   | –                   | 56,000                | bps               | 4     |
| Data Output:                 |                  |                       |                     |                       |                   |       |
| Logic Low                    | V <sub>OL</sub>  | –                     | 0.0                 | 0.1                   | VDC               | –     |
| Logic High                   | V <sub>OH</sub>  | V <sub>CC</sub> - 1.1 | V <sub>CC</sub> - 1 | V <sub>CC</sub> - 0.9 | VDC               | –     |
| Power Down Input:            |                  |                       |                     |                       |                   |       |
| Logic Low                    | V <sub>OL</sub>  | 0.0                   | –                   | 0.8                   | VDC               | –     |
| Logic High                   | V <sub>OH</sub>  | 2.8                   | –                   | V <sub>CC</sub>       | VDC               | –     |
| RSSI:                        |                  |                       |                     |                       |                   |       |
| Dynamic Range                | –                | –                     | 60                  | –                     | dB                | 4     |
| Gain                         | –                | –                     | 30                  | –                     | mV/dBm            | 4     |
| Voltage with No Carrier      | –                | –                     | 1.1                 | –                     | V                 | 4     |
| Voltage with Max Carrier     | –                | –                     | 2.9                 | –                     | V                 | 4     |
| <b>ANTENNA PORT</b>          |                  |                       |                     |                       |                   |       |
| RF Input Impedance           | R <sub>IN</sub>  | –                     | 50                  | –                     | Ω                 | 4     |
| <b>TIMING</b>                |                  |                       |                     |                       |                   |       |
| Receiver Turn-On Time:       |                  |                       |                     |                       |                   |       |
| Via V <sub>CC</sub>          | –                | 3.8                   | 4.7                 | 5.4                   | mSec              | 4,6   |
| Via PDN                      | –                | –                     | –                   | –                     | mSec              | 4,6   |
| Max Time Between Transitions | –                | –                     | 5.0                 | –                     | mSec              | 4,7   |
| <b>ENVIRONMENTAL</b>         |                  |                       |                     |                       |                   |       |
| Operating Temperature Range  | –                | 0                     | –                   | +70                   | °C                | 4     |

Table 1: ES Series Receiver Specifications

## Notes

1. Into a 50-ohm load.
2. For 10<sup>-5</sup> BER at 9,600 baud.
3. The audio bandwidth is wide to accommodate the needs of the data slicer. In audio applications, audio quality may be improved by using a low-pass filter rolling off at the maximum frequency of interest.
4. Characterized, but not tested.
5. Input frequency deviation-dependent.
6. Time to receiver readiness from the application of power to V<sub>CC</sub> or PDN going high.
7. Maximum time without a data transition.

# ABSOLUTE MAXIMUM RATINGS

|                                |                       |    |                       |     |
|--------------------------------|-----------------------|----|-----------------------|-----|
| Supply Voltage V <sub>CC</sub> | -0.3                  | to | +5.5                  | VDC |
| Any Input or Output Pin        | -0.3                  | to | V <sub>CC</sub> + 0.3 | VDC |
| Operating temperature          | 0                     | to | +70                   | °C  |
| Storage temperature            | -40                   | to | +125                  | °C  |
| Soldering temperature          | +260°C for 15 seconds |    |                       |     |

**\*NOTE\*** Exceeding any of the limits of this section may lead to permanent damage to the device. Furthermore, extended operation at these maximum ratings may reduce the life of this device.

## PERFORMANCE DATA

These performance parameters are based on module operation at 25°C from a 5.0VDC supply unless otherwise noted. Figure 2 illustrates the connections necessary for testing and operation. It is recommended all ground pins be connected to the ground plane. The pins marked NC have no electrical connection.

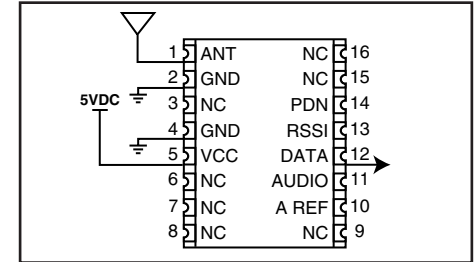

Figure 2: Test / Basic Application Circuit

## TYPICAL PERFORMANCE GRAPHS

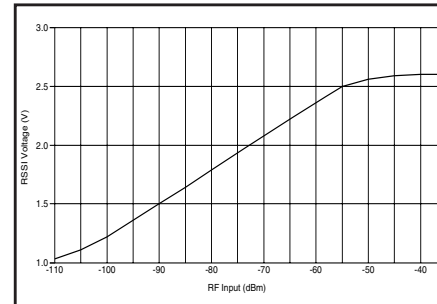

Figure 3: RSSI Characteristics Chart

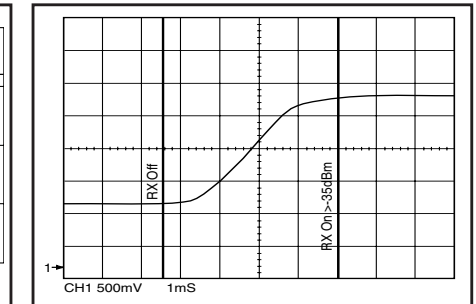

Figure 4: Worst Case RSSI Response Time

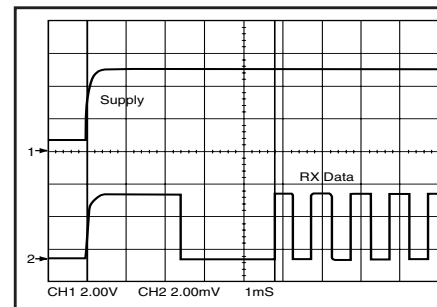

Figure 5: RX V<sub>cc</sub> to Valid Data

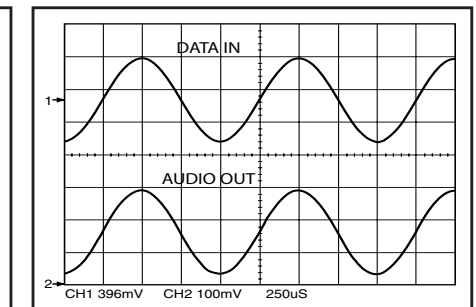

Figure 6: Sine-Wave Modulation Linearity

## PIN ASSIGNMENTS

|   |     |       |    |
|---|-----|-------|----|
| 1 | ANT | NC    | 16 |
| 2 | GND | NC    | 15 |
| 3 | NC  | PDN   | 14 |
| 4 | GND | RSSI  | 13 |
| 5 | VCC | DATA  | 12 |
| 6 | NC  | AUDIO | 11 |
| 7 | NC  | A REF | 10 |
| 8 | NC  | NC    | 9  |

Figure 7: ES Series Receiver Pinout (Top View)

## PIN DESCRIPTIONS

| Pin #   | Name            | Description  |
|---------|-----------------|--|
| 1       | ANT             | 50-ohm RF Input  |
| 2       | GND             | Analog Ground  |
| 3       | NC              | No Electrical Connection. Soldered for physical support only.  |
| 4       | GND             | Analog Ground  |
| 5       | V <sub>CC</sub> | Supply Voltage   |
| 6 - 9   | NC              | No Electrical Connection. Soldered for physical support only.  |
| 10      | A REF           | Audio RMS (Average) Voltage Reference  |
| 11      | AUDIO           | Recovered Analog Output  |
| 12      | DATA            | Digital Data Output. This line will output the demodulated digital data.   |
| 13      | RSSI            | Received Signal Strength Indicator. This line will supply an analog voltage that is proportional to the strength of the received signal.           |
| 14      | PDN             | Power Down. Pulling this line low will place the receiver into a low-current state. The module will not be able to receive a signal in this state. |
| 15 - 16 | NC              | No Electrical Connection. Soldered for physical support only.  |

## MODULE DESCRIPTION

The RXM-\*\*\*-ES module is a single-channel receiver designed for the wireless reception of digital or analog information over distances of up to 1,000 feet outdoors and up to 500 feet indoors. It is based on a high-performance, synthesized, single conversion, superhet architecture. FM / FSK modulation and SAW filtering are utilized to provide performance and noise immunity that are superior to AM-based solutions. The ES series is incredibly compact and cost-effective when compared with other FM / FSK devices. Best of all, it is packed with many useful features, offering a great deal of design flexibility.

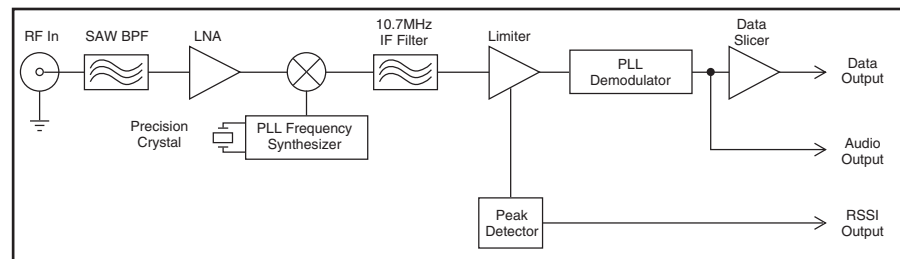

Figure 8: ES Series Receiver Block Diagram

## THEORY OF OPERATION

The receiver operates in a single conversion superhet configuration, with an IF of 10.7MHz and a baseband analog bandwidth of 28kHz. It is capable of receiving a signal as low as -97dBm (typical). The signal is filtered at the front end by a SAW band-pass filter. The filtered signal is then amplified and down-converted to the 10.7MHz IF by mixing it with a LO frequency generated by a PLL-locked VCO. The 10.7MHz IF is then amplified and filtered. Finally, a PLL demodulator is used to recover the baseband analog signal from the carrier. This analog signal is low-pass filtered and then output on the AUDIO line.

The analog output can be individual frequencies or complex waveforms, such as voice or music. The AUDIO line can also be used to recover unsquared data in instances where a designer wishes to use an external data slicer.

The ES receiver also features a high-performance on-board data slicer for recovery of data transmission. Its output is internally derived from the filtered analog baseband, which is squared and made externally available on the DATA line. The data slicer is capable of recreating squared waveforms from 100Hz to 28kHz, giving a data rate bandwidth of 200bps to 56kbps.

It is important to note that this receiver does not provide hysteresis or squelching of the DATA line. This means that in the absence of a valid transmission or transitional data, the DATA line will switch randomly. The effects of this noise must be considered and will be discussed in further detail later in this guide.

The receiver features a Received Signal Strength Indicator (RSSI) output. The RSSI pin outputs a linear voltage relative to the incoming signal level. This output has many valuable uses, including interference assessment, signal strength indication, external data squelching and qualification, and transmitter presence indication. Since RSSI values vary from part to part and correspond to signal strength and not necessarily distance, it is not recommended for range-finding applications.

## USING THE PDN PIN

The Power Down (PDN) line can be used to power down the receiver without the need for an external switch. This line has an internal pull-up, so when it is held high or simply left floating, the module will be active.

When the PDN line is pulled to ground, the receiver will enter into a low-current (<50 $\mu$ A) power-down mode. During this time the receiver is off and cannot perform any function. It may be useful to note that the startup time coming out of power-down will be slightly less than when applying  $V_{CC}$ .

The PDN line allows easy control of the receiver state from external components, like a microcontroller. By periodically activating the receiver, checking for data, then powering down, the receiver's average current consumption can be greatly reduced, saving power in battery-operated applications.

## USING THE RSSI PIN

The receiver's Received Signal Strength Indicator (RSSI) line serves a variety of uses. The RSSI line has a dynamic range of 60dB (typical) and outputs a voltage proportional to the incoming signal strength. A graph of the RSSI line's characteristics appears in the Typical Performance Graphs section. It should be realized that the RSSI levels and dynamic range will vary slightly from part to part. It is also important to remember that the RSSI output indicates the strength of any in-band RF energy and not necessarily just that from the intended transmitter; therefore, it should only be used to qualify the level and presence of a signal.

The RSSI output can be used to create external squelch circuits. It can be utilized during testing or even as a product feature to assess interference and channel quality by looking at the voltage level with all intended transmitters off. The RSSI output can also be used in direction-finding applications although there are many potential perils to consider in such systems. Finally, it can be used to save system power by "waking up" external circuitry when a transmission is received or crosses a certain threshold. The RSSI output feature adds tremendous versatility for the creative designer.

## POWER SUPPLY REQUIREMENTS

The module does not have an internal voltage regulator, therefore it requires a clean, well-regulated power source. While it is preferable to power the unit from a battery, it can also be operated from a power supply as long as noise is less than 20mV. Power supply noise can significantly affect the receiver sensitivity, therefore; providing clean power to the module should be a high priority during design.

A 10 $\Omega$  resistor in series with the supply followed by a 10 $\mu$ F tantalum capacitor from  $V_{CC}$  to ground will help in cases where the quality of the supply is poor. Note that the values may need to be adjusted depending on the noise present on the supply line.

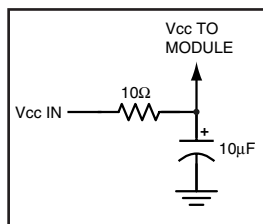

Figure 9: Supply Filter

## PROTOCOL GUIDELINES

While many RF solutions impose data formatting and balancing requirements, Linx RF modules do not encode or packetize the signal content in any manner. The received signal will be affected by such factors as noise, edge jitter, and interference, but it is not purposefully manipulated or altered by the modules. This gives the designer tremendous flexibility for protocol design and interface.

Despite this transparency and ease of use, it must be recognized that there are distinct differences between a wired and a wireless environment. Issues such as interference and contention must be understood and allowed for in the design process. To learn more about protocol considerations, we suggest you read Linx Application Note AN-00160.

Errors from interference or changing signal conditions can cause corruption of the data packet, so it is generally wise to structure the data being sent into small packets. This allows errors to be managed without affecting large amounts of data. A simple checksum or CRC could be used for basic error detection. Once an error is detected, the protocol designer may wish to simply discard the corrupt data or implement a more sophisticated scheme to correct it.

## INTERFERENCE CONSIDERATIONS

The RF spectrum is crowded and the potential for conflict with other unwanted sources of RF is very real. While all RF products are at risk from interference, its effects can be minimized by better understanding its characteristics.

Interference may come from internal or external sources. The first step is to eliminate interference from noise sources on the board. This means paying careful attention to layout, grounding, filtering, and bypassing in order to eliminate all radiated and conducted interference paths. For many products, this is straightforward; however, products containing components such as switching power supplies, motors, crystals, and other potential sources of noise must be approached with care. Comparing your own design with a Linx evaluation board can help to determine if and at what level design-specific interference is present.

External interference can manifest itself in a variety of ways. Low-level interference will produce noise and hashing on the output and reduce the link's overall range.

High-level interference is caused by nearby products sharing the same frequency or from near-band high-power devices. It can even come from your own products if more than one transmitter is active in the same area. It is important to remember that only one transmitter at a time can occupy a frequency, regardless of the coding of the transmitted signal. This type of interference is less common than those mentioned previously, but in severe cases it can prevent all useful function of the affected device.

Although technically it is not interference, multipath is also a factor to be understood. Multipath is a term used to refer to the signal cancellation effects that occur when RF waves arrive at the receiver in different phase relationships. This effect is a particularly significant factor in interior environments where objects provide many different signal reflection paths. Multipath cancellation results in lowered signal levels at the receiver and, thus, shorter useful distances for the link.

## USING THE RXM-\*\*\*-ES FOR ANALOG APPLICATIONS

The ES Series is an excellent choice for sending a wide range of analog information, including audio. The ability of the ES to receive combinations of analog and digital signals also opens new areas of opportunity for creative product design.

The transmission may contain simple or complex analog signals within the specified audio bandwidth. Signal sources ranging from a single frequency to complex content, such as audio, are handled with ease.

The AUDIO line of the receiver should be buffered and filtered to obtain maximum signal quality. This is particularly important because the audio output is AC-coupled, which means any DC loading will cause errors in the data slicer since data is derived from the audio voltage. For voice, a 3-4kHz low-pass filter is often employed. For broader-range sources, such as music, a 12-20kHz cutoff may be more appropriate. When only sending audio, the DATA line should be pulled to  $V_{CC}$  to reduce noise resulting from the data slicer switching.

The Signal-to-Noise Ratio (SNR) of the audio will depend on the bandwidth you select. The higher the SNR, the less hiss you will hear in the background. For the best SNR, choose the lowest filter cutoff appropriate for the intended signal. For applications that require true high fidelity, audio RF links designed expressly for this purpose may prove to be a more appropriate solution; however, a compandor may also be used with the ES Series transmitter to provide further SNR improvements.

The 360mV<sub>P-P</sub> output level of the AUDIO line is not sufficient to drive a speaker, so an amplifier will be required. This amplifier can also be used to provide the buffering and filtering described above. Some manufacturers make amplifiers specifically for audio applications, but standard filter designs, such as Butterworth or Sallen-Key, can also be used with success.

To avoid audible white noise or hiss when no transmission is present, a squelch circuit can be implemented to provide muting. This is easily accomplished with a circuit like the one shown below.

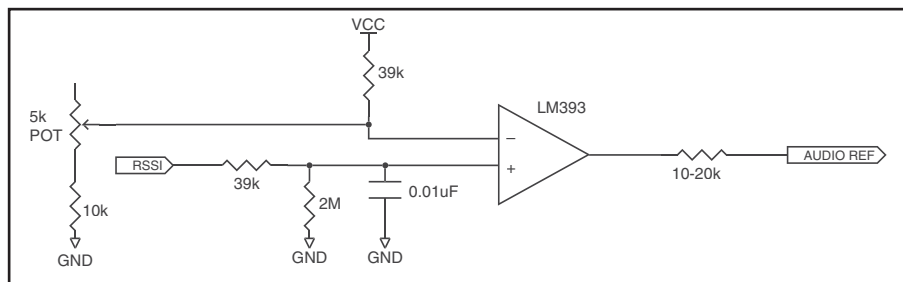

Figure 10: ES Series Receiver Squelch Circuit

Analog squelching is implemented by comparing the RSSI voltage to a voltage reference (typically a voltage divider) with an open collector-style comparator. When the RSSI voltage becomes lower than the voltage reference, the comparator output is pulled to ground, disabling the AUDIO output. This is useful because the analog circuit can be disabled either when the receiver is out of range or the transmitter is turned off. Of course it is the designer's responsibility to choose a squelch topology that best fits the specific needs of the product.

## USING THE ES FOR DIGITAL APPLICATIONS

As previously discussed, it is important to note that this receiver does not provide hysteresis or squelching of the DATA line. This means that in the absence of a valid transmission or transitional data, the DATA line will switch randomly. In many applications this hash will be ignored by the decoder or system software, but, depending on your application, it may be useful to add an external circuit to provide data squelching and hysteresis.

A squelch circuit will disable the DATA output when the RSSI voltage falls below a reference level. Hysteresis will make the RSSI voltage have to fall lower than the reference voltage before switching off, and to have to rise higher than the reference voltage before switching on. This will prevent low amplitude noise from causing the data line to switch, reducing hash during times that the transmitter is off or during transmitter steady-state times exceeding 5mS. Strong signals can still get through, so it is a good idea to have a noise tolerant protocol.

Creating a circuit that has additional hysteresis characteristics is very basic and requires very few parts thanks to the A REF line. All you need is a couple of resistors to provide some isolation for the AUDIO and A REF lines, a large feedback resistor, a pull-up resistor, and an open collector comparator.

The RSSI and A REF lines allow a wide variety of squelch circuits to be implemented. One such possibility is the circuit below, which is used on the ES Series Master Development System, and may be employed for audio or data squelching. It is ultimately the responsibility of the designer to determine what, if any, circuit would be most appropriate for the needs of the product.

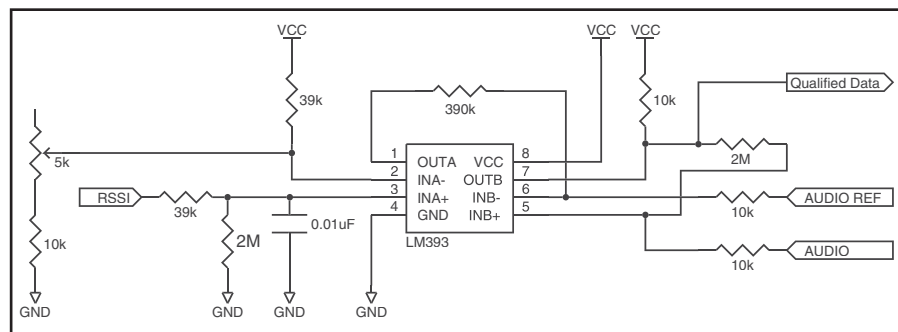

Figure 11: ES Series Receiver Squelch / Hysteresis Circuit

Data squelching in the circuit above is accomplished by comparing the RSSI voltage to a voltage reference (typically a voltage divider) with an open collector style comparator. When the voltage from the RSSI becomes lower than the voltage reference, the comparator output is pulled to GND. This is useful because this output can be used to disable the data-slicer circuit either when the receiver is out of range or the transmitter is turned off.

The squelch threshold will normally be set as low as possible to ensure maximum sensitivity and range. It is important to recognize that in many actual use environments, ambient noise and interference may enter the receiver at levels well above the squelch threshold. For this reason, it is always recommended that the product's protocol be structured to allow for the possibility of hashing even when an external squelch circuit is employed.

## BOARD LAYOUT GUIDELINES

If you are at all familiar with RF devices, you may be concerned about specialized board layout requirements. Fortunately, because of the care taken by Linx in designing the modules, integrating them is very straightforward. Despite this ease of application, it is still necessary to maintain respect for the RF stage and exercise appropriate care in layout and application in order to maximize performance and ensure reliable operation. The antenna can also be influenced by layout choices. Please review this data guide in its entirety prior to beginning your design. By adhering to good layout principles and observing some basic design rules, you will be on the path to RF success.

The adjacent figure shows the suggested PCB footprint for the module. The actual pad dimensions are shown in the Pad Layout section of this manual. A ground plane (as large as possible) should be placed on a lower layer of your PC board opposite the module. This ground plane can also be critical to the performance of your antenna, which will be discussed later. There should not be any ground or traces under the module on the same layer as the module, just bare PCB.

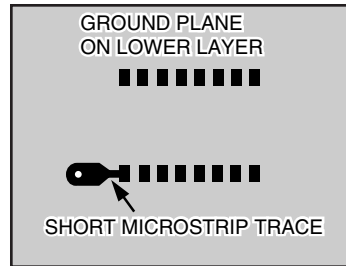

Figure 12: Suggested PCB Layout

During prototyping, the module should be soldered to a properly laid-out circuit board. The use of prototyping or “perf” boards will result in horrible performance and is strongly discouraged.

No conductive items should be placed within 0.15in of the module’s top or sides.

Do not route PCB traces directly under the module. The underside of the module has numerous signal-bearing traces and vias that could short or couple to traces on the product’s circuit board.

The module’s ground lines should each have their own via to the ground plane and be as short as possible.

AM / OOK receivers are particularly subject to noise. The module should, as much as reasonably possible, be isolated from other components on your PCB, especially high-frequency circuitry such as crystal oscillators, switching power supplies, and high-speed bus lines. Make sure internal wiring is routed away from the module and antenna, and is secured to prevent displacement.

The power supply filter should be placed close to the module’s  $V_{CC}$  line.

In some instances, a designer may wish to encapsulate or “pot” the product. Many Linx customers have done this successfully; however, there are a wide variety of potting compounds with varying dielectric properties. Since such compounds can considerably impact RF performance, it is the responsibility of the designer to carefully evaluate and qualify the impact and suitability of such materials.

The trace from the module to the antenna should be kept as short as possible. A simple trace is suitable for runs up to 1/8-inch for antennas with wide bandwidth characteristics. For longer runs or to avoid detuning narrow bandwidth antennas, such as a helical, use a 50-ohm coax or 50-ohm microstrip transmission line as described in the following section.

## MICROSTRIP DETAILS

A transmission line is a medium whereby RF energy is transferred from one place to another with minimal loss. This is a critical factor, especially in high-frequency products like Linx RF modules, because the trace leading to the module’s antenna can effectively contribute to the length of the antenna, changing its resonant bandwidth. In order to minimize loss and detuning, some form of transmission line between the antenna and the module should be used, unless the antenna can be placed very close (<1/8in.) to the module. One common form of transmission line is a coax cable, another is the microstrip. This term refers to a PCB trace running over a ground plane that is designed to serve as a transmission line between the module and the antenna. The width is based on the desired characteristic impedance of the line, the thickness of the PCB, and the dielectric constant of the board material. For standard 0.062in thick FR-4 board material, the trace width would be 111 mils. The correct trace width can be calculated for other widths and materials using the information below. Handy software for calculating microstrip lines is also available on the Linx website, [www.linxtechnologies.com](http://www.linxtechnologies.com).

$$E_e = \frac{E_r + 1}{2} + \frac{E_r - 1}{2} \cdot \frac{1}{\sqrt{1 + 12d/W}}$$

$$Z_0 = \begin{cases} \frac{60}{\sqrt{E_e}} \cdot \ln\left(\frac{8d}{W} + \frac{W}{4d}\right) & \text{For } \frac{W}{d} \leq 1 \\ \frac{120\pi}{\sqrt{E_e} \cdot \left(\frac{W}{d} + 1.393 + 0.667 \cdot \ln\left(\frac{W}{d} + 1.444\right)\right)} & \text{For } \frac{W}{d} \geq 1 \end{cases}$$

$E_r$  = Dielectric constant of PCB material

Figure 13: Microstrip Formulas

| Dielectric Constant | Width/Height (W/d) | Effective Dielectric Constant | Characteristic Impedance |
|---------------------|--------------------|-------------------------------|--------------------------|
| 4.80                | 1.8                | 3.59                          | 50.0                     |
| 4.00                | 2.0                | 3.07                          | 51.0                     |
| 2.55                | 3.0                | 2.12                          | 48.0                     |

## PAD LAYOUT

The following pad layout diagram is designed to facilitate both hand and automated assembly.

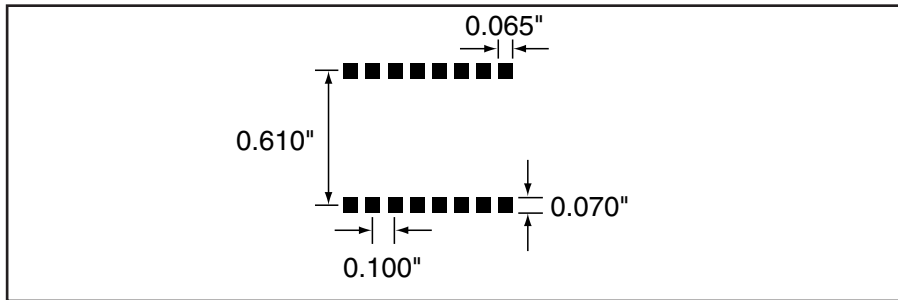

Figure 14: Recommended PCB Layout

## PRODUCTION GUIDELINES

The modules are housed in a hybrid SMD package that supports hand or automated assembly techniques. Since the modules contain discrete components internally, the assembly procedures are critical to ensuring the reliable function of the modules. The following procedures should be reviewed with and practiced by all assembly personnel.

## HAND ASSEMBLY

Pads located on the bottom of the module are the primary mounting surface. Since these pads are inaccessible during mounting, castellations that run up the side of the module have been provided to facilitate solder wicking to the module's underside. This allows for very quick hand soldering for prototyping and small volume production.

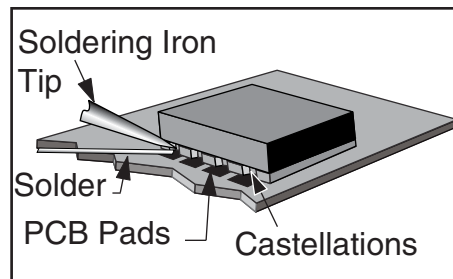

Figure 15: Soldering Technique

If the recommended pad guidelines have been followed, the pads will protrude slightly past the edge of the module. Use a fine soldering tip to heat the board pad and the castellation, then introduce solder to the pad at the module's edge. The solder will wick underneath the module, providing reliable attachment. Tack one module corner first and then work around the device, taking care not to exceed the times listed below.

### Absolute Maximum Solder Times

**Hand-Solder Temp. TX +225°C for 10 Seconds**

**Hand-Solder Temp. RX +225°C for 10 Seconds**

**Recommended Solder Melting Point +180°C**

**Reflow Oven: +220°C Max. (See adjoining diagram)**

## AUTOMATED ASSEMBLY

For high-volume assembly, most users will want to auto-place the modules. The modules have been designed to maintain compatibility with reflow processing techniques; however, due to their hybrid nature, certain aspects of the assembly process are far more critical than for other component types.

Following are brief discussions of the three primary areas where caution must be observed.

### Reflow Temperature Profile

The single most critical stage in the automated assembly process is the reflow stage. The reflow profile below should not be exceeded, since excessive temperatures or transport times during reflow will irreparably damage the modules. Assembly personnel will need to pay careful attention to the oven's profile to ensure that it meets the requirements necessary to successfully reflow all components while still remaining within the limits mandated by the modules. The figure below shows the recommended reflow oven profile for the modules.

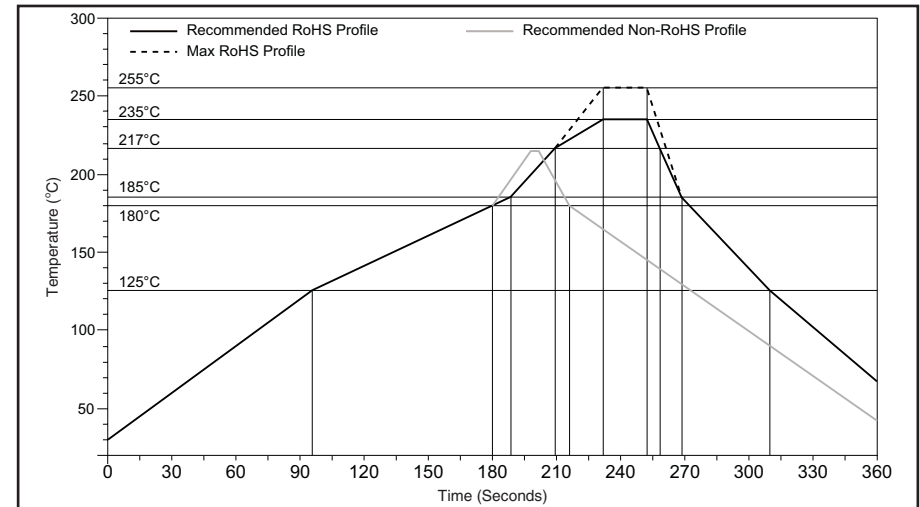

Figure 16: Maximum Reflow Profile

### Shock During Reflow Transport

Since some internal module components may reflow along with the components placed on the board being assembled, it is imperative that the modules not be subjected to shock or vibration during the time solder is liquid. Should a shock be applied, some internal components could be lifted from their pads, causing the module to not function properly.

### Washability

The modules are wash resistant, but are not hermetically sealed. Linx recommends wash-free manufacturing; however, the modules can be subjected to a wash cycle provided that a drying time is allowed prior to applying electrical power to the modules. The drying time should be sufficient to allow any moisture that may have migrated into the module to evaporate, thus eliminating the potential for shorting damage during power-up or testing. If the wash contains contaminants, the performance may be adversely affected, even after drying.

## ANTENNA CONSIDERATIONS

The choice of antennas is a critical and often overlooked design consideration. The range, performance, and legality of an RF link are critically dependent upon the antenna. While adequate antenna performance can often be obtained by trial and error methods, antenna design and matching is a complex task. A professionally designed antenna, such as those from Linx, will help ensure maximum performance and FCC compliance.

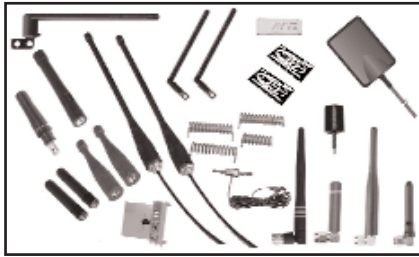

Figure 17: Linx Antennas

Linx transmitter modules typically have an output power that is slightly higher than the legal limits. This allows the designer to use an inefficient antenna, such as a loop trace or helical, to meet size, cost, or cosmetic requirements and still achieve full legal output power for maximum range. If an efficient antenna is used, then some attenuation of the output power will likely be needed. This can easily be accomplished by using the LADJ line or a T-pad attenuator. For more details on T-pad attenuator design, please see Application Note AN-00150.

A receiver antenna should be optimized for the frequency or band in which the receiver operates and to minimize the reception of off-frequency signals. The efficiency of the receiver's antenna is critical to maximizing range performance. Unlike the transmitter antenna, where legal operation may mandate attenuation or a reduction in antenna efficiency, the receiver's antenna should be optimized as much as is practical.

It is usually best to utilize a basic quarter-wave whip until your prototype product is operating satisfactorily. Other antennas can then be evaluated based on the cost, size, and cosmetic requirements of the product. You may wish to review Application Note AN-00500 "Antennas: Design, Application, Performance"

## ANTENNA SHARING

In cases where a transmitter and receiver module are combined to form a transceiver, it is often advantageous to share a single antenna. To accomplish this, an antenna switch must be used to provide isolation between the modules so that the full transmitter output power is not put on the sensitive front end of the receiver. There are a wide variety of antenna switches that are cost-effective and easy to use. Among the most popular are switches from Macom and NEC. Look for an antenna switch that has high isolation and low loss at the desired frequency of operation. Generally, the Tx or Rx status of a switch will be controlled by a product's microprocessor, but the user may also make the selection manually. In some cases, where the characteristics of the Tx and Rx antennas need to be different or antenna switch losses are unacceptable, it may be more appropriate to utilize two discrete antennas.

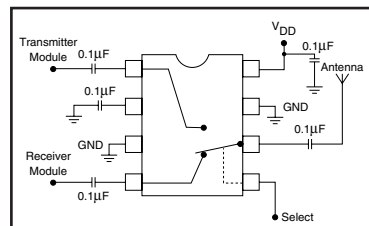

Figure 18: Typical Antenna Switch

## GENERAL ANTENNA RULES

The following general rules should help in maximizing antenna performance.

1. Proximity to objects such as a user's hand, body, or metal objects will cause an antenna to detune. For this reason, the antenna shaft and tip should be positioned as far away from such objects as possible.

2. Optimum performance will be obtained from a 1/4- or 1/2-wave straight whip mounted at a right angle to the ground plane. In many cases, this isn't desirable for practical or ergonomic reasons, thus, an alternative antenna style such as a helical, loop, or patch may be utilized

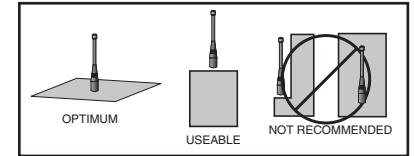

Figure 19: Ground Plane Orientation

3. If an internal antenna is to be used, keep it away from other metal components, particularly large items like transformers, batteries, PCB tracks, and ground planes. In many cases, the space around the antenna is as important as the antenna itself. Objects in close proximity to the antenna can cause direct detuning, while those farther away will alter the antenna's symmetry.

4. In many antenna designs, particularly 1/4-wave whips, the ground plane acts as a counterpoise, forming, in essence, a 1/2-wave dipole. For this reason, adequate ground plane area is essential. The ground plane can be a metal case or ground-fill areas on a circuit board. Ideally, it should have a surface area  $\geq$  the overall length of the 1/4-wave radiating element. This is often not practical due to size and configuration constraints. In these instances, a designer must make the best use of the area available to create as much ground plane as possible in proximity to the base of the antenna. In cases where the antenna is remotely located or the antenna is not in close proximity to a circuit board, ground plane, or grounded metal case, a metal plate may be used to maximize the antenna's performance.

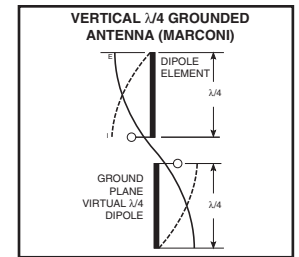

Figure 20: Dipole Antenna

5. Remove the antenna as far as possible from potential interference sources. Any frequency of sufficient amplitude to enter the receiver's front end will reduce system range and can even prevent reception entirely. Switching power supplies, oscillators, or even relays can also be significant sources of potential interference. The single best weapon against such problems is attention to placement and layout. Filter the module's power supply with a high-frequency bypass capacitor. Place adequate ground plane under potential sources of noise to shunt noise to ground and prevent it from coupling to the RF stage. Shield noisy board areas whenever practical.

6. In some applications, it is advantageous to place the module and antenna away from the main equipment. This can avoid interference problems and allows the antenna to be oriented for optimum performance. Always use 50Ω coax, like RG-174, for the remote feed.

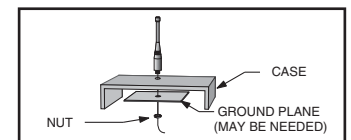

Figure 21: Remote Ground Plane

## COMMON ANTENNA STYLES

There are literally hundreds of antenna styles and variations that can be employed with Linx RF modules. Following is a brief discussion of the styles most commonly utilized. Additional antenna information can be found in Linx Application Notes AN-00100, AN-00140, and AN-00500. Linx antennas and connectors offer outstanding performance at a low price.

### Whip Style



$$L = \frac{234}{F} \text{ MHz}$$

Where:  
*L* = length in feet of quarter-wave length  
*F* = operating frequency in megahertz

A whip-style antenna provides outstanding overall performance and stability. A low-cost whip is can be easily fabricated from a wire or rod, but most designers opt for the consistent performance and cosmetic appeal of a professionally-made model. To meet this need, Linx offers a wide variety of straight and reduced-height whip-style antennas in permanent and connectorized mounting styles.

The wavelength of the operational frequency determines an antenna's overall length. Since a full wavelength is often quite long, a partial 1/2- or 1/4-wave antenna is normally employed. Its size and natural radiation resistance make it well matched to Linx modules. The proper length for a straight 1/4-wave can be easily determined using the adjacent formula. It is also possible to reduce the overall height of the antenna by using a helical winding. This reduces the antenna's bandwidth, but is a great way to minimize the antenna's physical size for compact applications. This also means that the physical appearance is not always an indicator of the antenna's frequency.

### Specialty Styles



Linx offers a wide variety of specialized antenna styles. Many of these styles utilize helical elements to reduce the overall antenna size while maintaining reasonable performance. A helical antenna's bandwidth is often quite narrow and the antenna can detune in proximity to other objects, so care must be exercised in layout and placement.

### Loop Style



A loop- or trace-style antenna is normally printed directly on a product's PCB. This makes it the most cost-effective of antenna styles. The element can be made self-resonant or externally resonated with discrete components, but its actual layout is usually product specific. Despite the cost advantages, loop-style antennas are generally inefficient and useful only for short-range applications. They are also very sensitive to changes in layout and PCB dielectric, which can cause consistency issues during production. In addition, printed styles are difficult to engineer, requiring the use of expensive equipment, including a network analyzer. An improperly designed loop will have a high SWR at the desired frequency, which can cause instability in the RF stage.



Linx offers low-cost planar and chip antennas that mount directly to a product's PCB. These tiny antennas do not require testing and provide excellent performance in light of their small size. They offer a preferable alternative to the often-problematic "printed" antenna.

## ONLINE RESOURCES



[www.linxtechnologies.com](http://www.linxtechnologies.com)

- Latest News
- Data Guides
- Application Notes
- Knowledgebase
- Software Updates



If you have questions regarding any Linx product and have Internet access, make [www.linxtechnologies.com](http://www.linxtechnologies.com) your first stop. Our website is organized in an intuitive format to immediately give you the answers you need. Day or night, the Linx website gives you instant access to the latest information regarding the products and services of Linx. It's all here: manual and software updates, application notes, a comprehensive knowledgebase, FCC information, and much more. Be sure to visit often!



[www.antennafactor.com](http://www.antennafactor.com)

The Antenna Factor division of Linx offers a diverse array of antenna styles, many of which are optimized for use with our RF modules. From innovative embeddable antennas to low-cost whips, domes to Yagis, and even GPS, Antenna Factor likely has an antenna for you, or can design one to meet your requirements.



[www.connectorcity.com](http://www.connectorcity.com)

Through its Connector City division, Linx offers a wide selection of high-quality RF connectors, including FCC-compliant types such as RP-SMAs that are an ideal match for our modules and antennas. Connector City focuses on high-volume OEM requirements, which allows standard and custom RF connectors to be offered at a remarkably low cost.



## LEGAL CONSIDERATIONS

**NOTE:** Linx RF modules are designed as component devices that require external components to function. The modules are intended to allow for full Part 15 compliance; however, they are not approved by the FCC or any other agency worldwide. The purchaser understands that approvals may be required prior to the sale or operation of the device, and agrees to utilize the component in keeping with all laws governing its use in the country of operation.

When working with RF, a clear distinction must be made between what is technically possible and what is legally acceptable in the country where operation is intended. Many manufacturers have avoided incorporating RF into their products as a result of uncertainty and even fear of the approval and certification process. Here at Linx, our desire is not only to expedite the design process, but also to assist you in achieving a clear idea of what is involved in obtaining the necessary approvals to legally market your completed product.

In the United States, the approval process is actually quite straightforward. The regulations governing RF devices and the enforcement of them are the responsibility of the Federal Communications Commission (FCC). The regulations are contained in Title 47 of the Code of Federal Regulations (CFR). Title 47 is made up of numerous volumes; however, all regulations applicable to this module are contained in Volume 0-19. It is strongly recommended that a copy be obtained from the Government Printing Office in Washington or from your local government bookstore. Excerpts of applicable sections are included with Linx evaluation kits or may be obtained from the Linx Technologies website, [www.linxtechnologies.com](http://www.linxtechnologies.com). In brief, these rules require that any device that intentionally radiates RF energy be approved, that is, tested for compliance and issued a unique identification number. This is a relatively painless process. Linx offers full EMC pre-compliance testing in our HP / Emco-equipped test center. Final compliance testing is then performed by one of the many independent testing laboratories across the country. Many labs can also provide other certifications that the product may require at the same time, such as UL, CLASS A / B, etc. Once your completed product has passed, you will be issued an ID number that is to be clearly placed on each product manufactured.

Questions regarding interpretations of the Part 2 and Part 15 rules or measurement procedures used to test intentional radiators, such as Linx RF modules, for compliance with the technical standards of Part 15, should be addressed to:

Federal Communications Commission  
 Equipment Authorization Division  
 Customer Service Branch, MS 1300F2  
 7435 Oakland Mills Road  
 Columbia, MD 21046

Phone: (301) 725-1585 Fax: (301) 344-2050 E-Mail: [labinfo@fcc.gov](mailto:labinfo@fcc.gov)

International approvals are slightly more complex, although Linx modules are designed to allow all international standards to be met. If you are considering the export of your product abroad, you should contact Linx Technologies to determine the specific suitability of the module to your application.

All Linx modules are designed with the approval process in mind and thus much of the frustration that is typically experienced with a discrete design is eliminated. Approval is still dependent on many factors, such as the choice of antennas, correct use of the frequency selected, and physical packaging. While some extra cost and design effort are required to address these issues, the additional usefulness and profitability added to a product by RF makes the effort more than worthwhile.

## ACHIEVING A SUCCESSFUL RF IMPLEMENTATION

Adding an RF stage brings an exciting new dimension to any product. It also means that additional effort and commitment will be needed to bring the product successfully to market. By utilizing premade RF modules, such as the LR Series, the design and approval process is greatly simplified. It is still important, however, to have an objective view of the steps necessary to ensure a successful RF integration. Since the capabilities of each customer vary widely, it is difficult to recommend one particular design path, but most projects follow steps similar to those shown at the right.

In reviewing this sample design path, you may notice that Linx offers a variety of services (such as antenna design and FCC prequalification) that are unusual for a high-volume component manufacturer. These services, along with an exceptional level of technical support, are offered because we recognize that RF is a complex science requiring the highest caliber of products and support. "Wireless Made Simple" is more than just a motto, it's our commitment. By choosing Linx as your RF partner and taking advantage of the resources we offer, you will not only survive implementing RF, you may even find the process enjoyable.

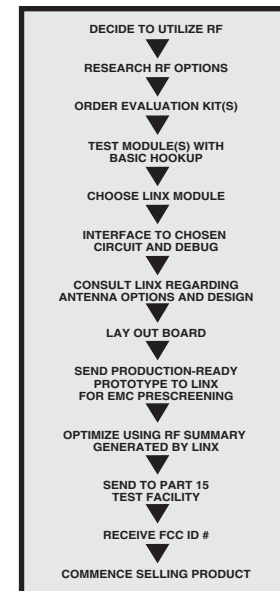

**Typical Steps For Implementing RF**

## HELPFUL APPLICATION NOTES FROM LINX

It is not the intention of this manual to address in depth many of the issues that should be considered to ensure that the modules function correctly and deliver the maximum possible performance. As you proceed with your design, you may wish to obtain one or more of the following application notes, which address in depth key areas of RF design and application of Linx products. These applications notes are available online at [www.linxtechnologies.com](http://www.linxtechnologies.com) or by contacting the Linx literature department.

| NOTE     | APPLICATION NOTE TITLE                                  |
|----------|---|
| AN-00100 | RF 101: Information for the RF Challenged               |
| AN-00126 | Considerations For Operation Within The 902-928MHz Band |
| AN-00130 | Modulation Techniques For Low-Cost RF Data Links        |
| AN-00140 | The FCC Road: Part 15 From Concept To Approval          |
| AN-00160 | Considerations For Sending Data Over a Wireless Link    |
| AN-00500 | Antennas: Design, Application, Performance              |



## U.S. CORPORATE HEADQUARTERS

### **LINX TECHNOLOGIES, INC.**

**159 ORT LANE  
MERLIN, OR 97532**

**PHONE: (541) 471-6256**

**FAX: (541) 471-6251**

**[www.linxtechnologies.com](http://www.linxtechnologies.com)**

### **Disclaimer**

Linx Technologies is continually striving to improve the quality and function of its products. For this reason, we reserve the right to make changes to our products without notice. The information contained in this Overview Guide is believed to be accurate as of the time of publication. Specifications are based on representative lot samples. Values may vary from lot-to-lot and are not guaranteed. "Typical" parameters can and do vary over lots and application. Linx Technologies makes no guarantee, warranty, or representation regarding the suitability of any product for use in any specific application. It is the customer's responsibility to verify the suitability of the part for the intended application. NO LINX PRODUCT IS INTENDED FOR USE IN ANY APPLICATION WHERE THE SAFETY OF LIFE OR PROPERTY IS AT RISK.

Linx Technologies DISCLAIMS ALL WARRANTIES OF MERCHANTABILITY AND FITNESS FOR A PARTICULAR PURPOSE. IN NO EVENT SHALL LINX TECHNOLOGIES BE LIABLE FOR ANY OF CUSTOMER'S INCIDENTAL OR CONSEQUENTIAL DAMAGES ARISING IN ANY WAY FROM ANY DEFECTIVE OR NON-CONFORMING PRODUCTS OR FOR ANY OTHER BREACH OF CONTRACT BY LINX TECHNOLOGIES. The limitations on Linx Technologies' liability are applicable to any and all claims or theories of recovery asserted by Customer, including, without limitation, breach of contract, breach of warranty, strict liability, or negligence. Customer assumes all liability (including, without limitation, liability for injury to person or property, economic loss, or business interruption) for all claims, including claims from third parties, arising from the use of the Products. The Customer will indemnify, defend, protect, and hold harmless Linx Technologies and its officers, employees, subsidiaries, affiliates, distributors, and representatives from and against all claims, damages, actions, suits, proceedings, demands, assessments, adjustments, costs, and expenses incurred by Linx Technologies as a result of or arising from any Products sold by Linx Technologies to Customer. Under no conditions will Linx Technologies be responsible for losses arising from the use or failure of the device in any application, other than the repair, replacement, or refund limited to the original product purchase price. Devices described in this publication may contain proprietary, patented, or copyrighted techniques, components, or materials. Under no circumstances shall any user be conveyed any license or right to the use or ownership of such items.