

1		
Description	Material	Finish
Body	Brass	Gold
Socket	BE CU	Gold
Insulation	Teflon	Teflon
Support	Brass	Gold
Spacer	Teflon	Teflon

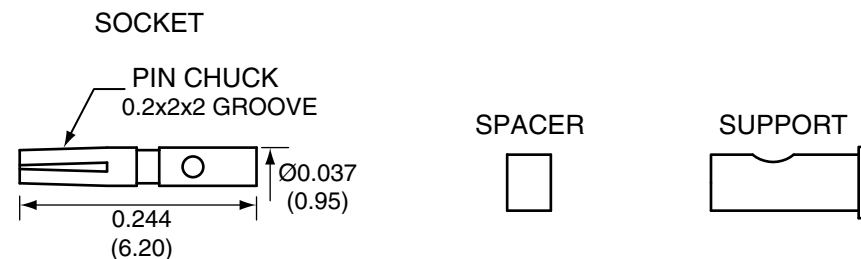

RECOMMENDED CABLE STRIPPING DIMENSIONS

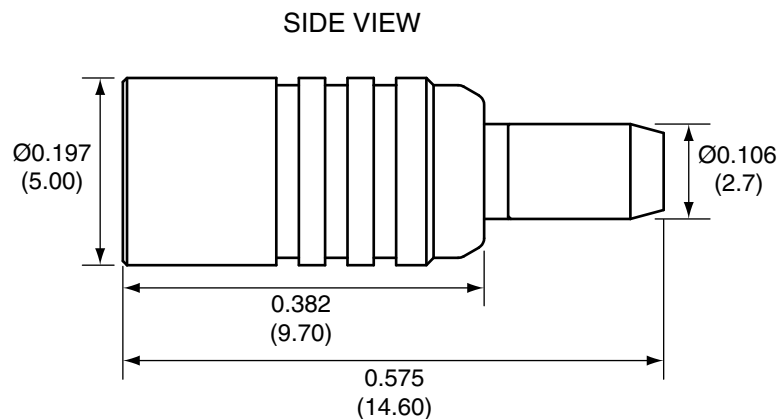
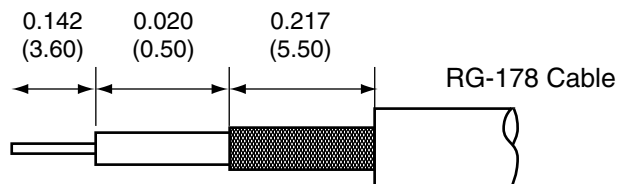

CONMCX011-R178 ASSEMBLY INSTRUCTIONS

1. Strip the cable to the recommended dimensions.
2. Solder the support onto the braid.
3. Place the spacer onto the center conductor.
4. Solder or crimp the socket onto the center conductor.
5. Insert the socket, center conductor, spacer, and support into the body until the socket snaps in.
6. Crimp the tail of the body onto the support with a hex crimp tool.

Title MCX FEMALE CABLE END CRIMP FOR RG178/U and RG196/U CABLE		CONNECTOR CITY 159 ORT LANE MERLIN, OR 97532 PH (541)-471-6256 FAX (541)-471-6251	
Part No. CONMCX011-R178	Revision: 1.1		
Dimensions: INCHES (mm)	Date: 7/23/2008	Sheet 1 of 1	

CONNECTOR CITY
THE VALUE OF CONNECTIONS