

Description	Material	Finish
Body	Brass	Gold
Pin	Brass	Gold
Insulation	Teflon	Teflon
Lock Washer	BE CU	Gold
Crimp Ring	Brass	Gold
Heat Shrink	Polyolefin	Black

REVISIONS			
REV	DESCRIPTION	DATE	APPV
A	Initial release	1/13/10	CJ

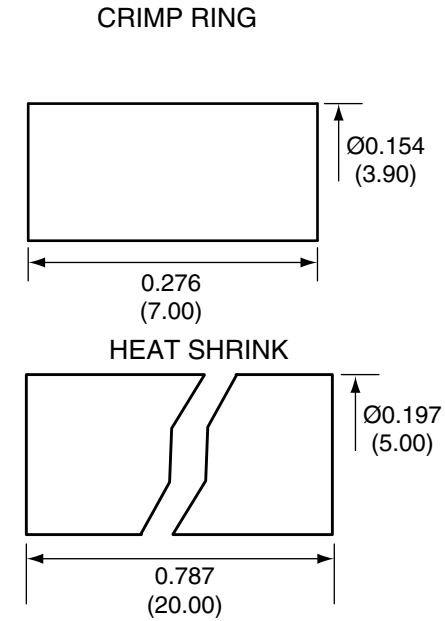
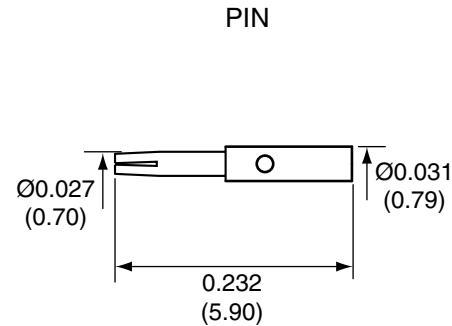
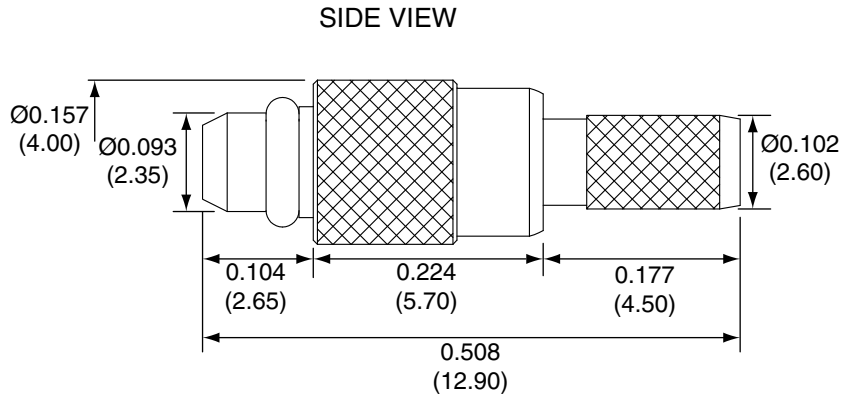

CONREVMCX007 ASSEMBLY INSTRUCTIONS

1. Solder the pin to the center conductor.
2. Insert the pin, center conductor, and insulator into the body until the top of the pin is even with the body.
3. Wrap the braid around the tail of the body and crimp the ring with a 0.137" hex crimp tool (or one labeled for use with RG-174 cable).

NOTES: (UNLESS OTHERWISE SPECIFIED)

1. ALL DIMENSIONS ARE IN INCHES [mm].
2. DIMENSIONS APPLY AFTER FINISHING.
3. MANUFACTURE TO BE COMPLIANT WITH EU RoHS DIRECTIVE.
4. SAFETY BREAK ALL SHARP CORNERS AND EDGES .02 MAXIMUM.

RECOMMENDED CABLE STRIPPING DIMENSIONS

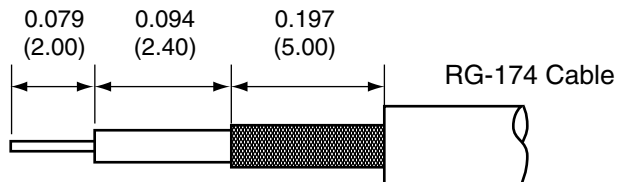

WARNING: THIS DRAWING CONTAINS PROPRIETARY INFORMATION THAT IS THE SOLE PROPERTY OF CONNECTOR CITY, AND SHALL BE TREATED AS SUCH. NO DISCLOSURE OR REPRODUCTION OF THIS DOCUMENT IS PERMITTED, IN WHOLE OR IN PART, WITHOUT THE EXPRESS WRITTEN PERMISSION OF CONNECTOR CITY OR ITS DESIGNATED AGENTS.

CONNECTOR CITY 159 ORT LANE
THE VALUE OF CONNECTIONS MERLIN, OR 97532

MATERIAL:	TOLERANCES: .020 [0.50]-.200 [5.00]= ± .008 [0.20] .200 [5.00]-1.200 [30.00]= ± .016 [0.40] 1.20 [30.0]-4.75 [120.0]= ± .024 [0.60] 4.75 [120.0]-12.40 [315.0]= ± .040 [1.0]	PROJECTION:
FINISH:	DRAWN: CJ	DT: 1/13/10
	ENGR:	DT:

TITLE: MMCX-RP MALE CABLE END CRIMP FOR RG174 CABLE	SIZE A	DWG. NO. CONREVMCX007	REV A
SCALE: 2:1	DO NOT SCALE DRAWING	SHEET 1 OF 1	